

Piotr MILEWSKI<sup>1</sup>  
Mirosław BRONIEWICZ<sup>2</sup>

## RESISTANCE OF THE WELDS IN CHS JOINTS WITH THE RIB PLATES

With regard to the calculation of welds' resistance in connections between hollow sections in EN 1993-1-8, very general information is given without any indication of specific calculation procedures. These recommendations are basically as follows: the resistance of the welds must have the value of the cross-section and assessment of the welds' resistance based on the effective lengths is allowed in cases when forces in the braces are smaller than the resistance of the joint, but the detailed method is not specified. The objective of this paper is to present the most up-to-date information for the design of welds for overlap joints with reinforcing rib plates. The article presents the FEM analysis of the welds in the intermediate joint with the rib in a truss made of circular hollow sections. The conclusions from the analysis were presented.

**Keywords:** trusses, hollow sections, K joint with the ribs, welds, FEM analysis

### 1. Introduction

#### 1.1. Welded joints made of hollow sections

Welded joints of trusses made of hollow sections with the reinforcing rib plates between braces occur mainly in assembly joints of chords (Fig. 1) and in support joints (Fig. 2) [1]. Similar solutions are also found in the case of design of overlap joints when there is little overlap of braces ( $\lambda_{ov} < 25\%$ ). For executive reasons, joints with rib plates are used in the case of technological difficulties in the proper execution of welds on covered sections of joining members or in order to avoid welding accumulation. The ribs are also used in K type intermediate joints of lattice systems when it is necessary to attach an additional structural element to the joint (Fig. 3).

---

<sup>1</sup> Corresponding author: Piotr Milewski, Białystok University of Technology, ul. Wiejska 45A, milewski.piotr@o2.pl, praca badawcza MB/WBiIS/5/16

<sup>2</sup> Mirosław Broniewicz, Białystok University of Technology, ul. Wiejska 45A, m.broniewicz@pb.edu.pl

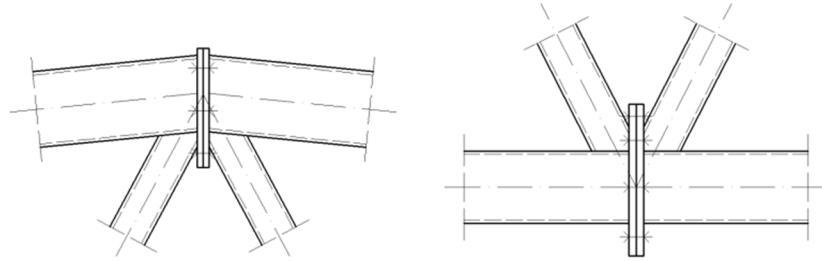

Fig. 1. Midspan assembly joints

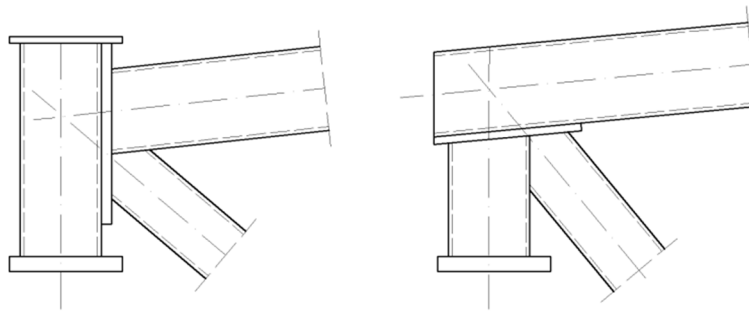

Fig. 2. Support of a truss on an outer column

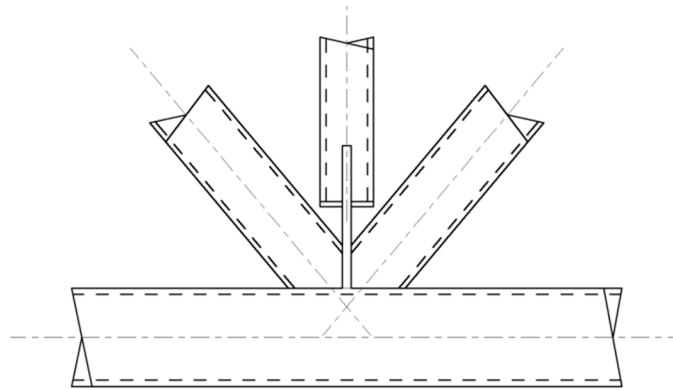

Fig. 3. Joint with the head rib and an additional post

## 1.2. Assessment of the resistance of fillet welds

The principles for the assessment of the joints capacity made of hollow sections are given in PN-EN 1993-1-8 [2], in many monographs [3], [4] and CIDECT guides. To assess the capacity of joints with the ribs, the formulas given in PN-EN 1993-1-8 [2] can be used, referring to K joints with mutual overlap of the braces [4]. However, the calculation of welds resistance in welded

joints of members in lattice girders made of hollow sections has been treated in the PN-EN 1993-1-8 [2] very generally without providing detailed calculation guidelines. The procedure for assessing the capacity of T, Y and X joints as well as K and N joints with the gap was presented by Bródka and Broniewicz in publications [5] and [6]. Calculation of the resistance of welded K and N overlap joints made of rectangular and square hollow sections are given in the publication [7].

In all examined joints fillet welds with effective lengths calculated on the basis of experimental research were used. The assessment method presented in Annex K to the pre-standard EN 1993-1-1 [7] has been adopted as the basis for assessing the effective lengths of welds, with respect to gap joints made of rectangular hollow sections. It is stated that in the case of K and N joints at the angle of inclination of the braces  $\theta_i \leq 50^\circ$ , both transverse welds are effective in transferring of stresses and the total length of welds is  $l_w = 2(h_i / \sin \theta_i + b_i)$ , while in the case  $\theta_i \leq 60^\circ$  the transverse weld located on the acute angle does not participate in the stress transfer and  $l_w = 2h_i / \sin \theta_i + b_i$ .

According to the standard PN-EN 1993-1-8 [2], design effective lengths should be used in cases of welded joints made of fillet or groove welds when the forces in the braces are smaller than the capacity of the joints due to occurrence of general instability of members or unification their cross-sections. In such cases it is uneconomic to use the standard criterion so that the design resistance of the weld per unit length of the circumference of the brace is not less than the design resistance of the cross-section of this brace per unit of its circumference. In addition, it may be difficult to properly position of the welds with the required thickness, especially on sections of the inclined member at an obtuse angle.

The presented indications cannot be extended to the assessment of the resistance of welds in the joints with the rib plate, as the cutting of the ends of the joined sections is different, so the effective lengths and often the shapes of fillet or groove welds are different. The rules for calculating the capacity of such connections are presented in [9].

### 1.3. Welded joints with the rib plate made of circular hollow sections

In welded trusses joints made of hollow circular sections between the brace members and chords, depending on the location of the weld on the circumference of the member butt welds, fillet welds or groove welds are designed. In the case of using circular hollow sections at the contact points of the brace with the upper wall of the chord, fillet or butt welds are used, with the appropriate method of beveling of the walls of the circular member, while at the contact points of the brace with the side wall of the chord the groove welds are used. In the case of rectangular hollow sections, when the width of the brace is smaller than the width of the chord, fillet welds are used, or butt welds when the width of the brace is equal to the width of the chord.

In the paper [1], it was pointed out that the formulas, given in PN-EN 1993-1-8 [2], referring to assessing of the capacity of joints with mutual overlapping of the brace members, can be used to assess capacity of such joints with a rib plate. The evaluation of the resistance of fillet welds laid in connection of the braces with the rib plate is different due to the different way of cutting the ends of joined members. The effective lengths of the welds and the shapes of fillet or groove welds are also different.

Fig. 4 shows the intermediate welded K-joint of the bottom truss chord made of circular hollow sections with the same diameter of the brace members. Due to the low overlap value of the braces, in order to avoid welds along the spatial curve, which imitates the contact of the brace with the chord, a rib plate has been used.

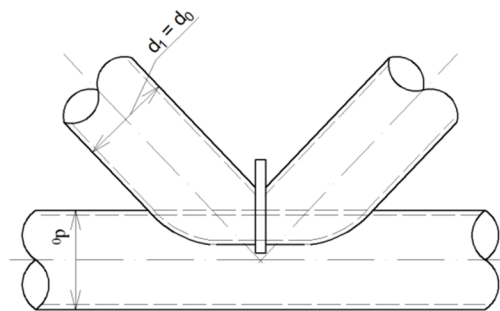

Fig. 4. Joint made of circular hollow sections with a reinforcing rib plate

Preparing the ends of circular members according to a specific spatial curve, ensuring proper matching of connecting elements is possible using modern, numerically controlled cutting machines. Making the right welded joints requires chamfering of walls with different angle of inclination. The spatial shape of the joint, as well as the variability of the type of weld in its length and its cross-section, make it difficult to assess the capacity of such welds. The thickness of such welds should be determined in accordance with their shapes, usually treated them as fillet or groove welds.

An exemplary arrangement of welds in the connection of braces with a chord in a K-joint with the rib plate made of circular hollow sections, at the inclination angle of the braces to the chord  $\theta_i \leq 50^\circ$  is shown in Fig. 5.

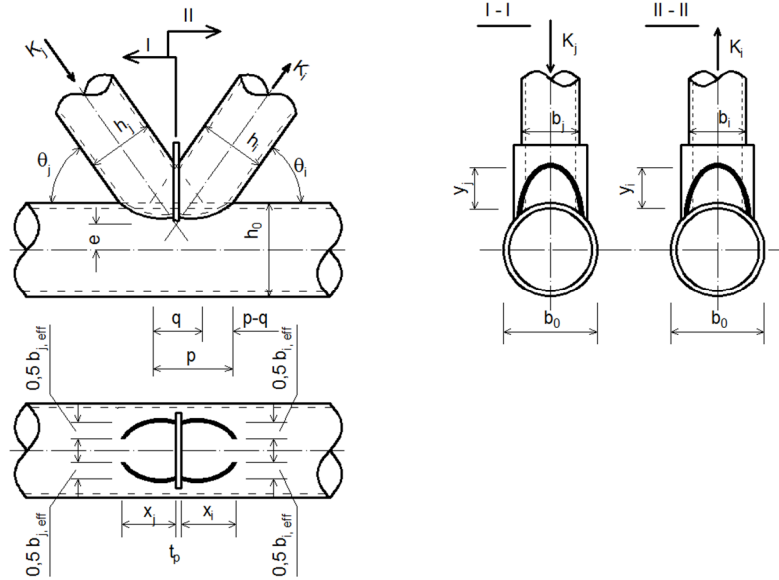

Fig. 5. Welds layout in circular hollow section overlap joint with reinforcing rib plate

An analytical method for determining the effective lengths of welds of such a joint is presented in the publication [8]. The values of mutual overlapping of braces  $q$  and  $p$  were evaluated in accordance with PN-EN 1993-1-8 [2]. The rib plate is connected to both the braces and the chord and participates in transferring forces from the braces to the chord. In order to determine the capacity of welded joints between the braces and the chord and the rib plate, the thickness of individual weld sections and their effective lengths  $x_j$ ,  $x_i$ ,  $y_j$ ,  $y_i$ ,  $b_{i,eff}$  and  $b_{j,eff}$  were determined. The values of  $x_j$ ,  $x_i$  are the effective lengths of welds connecting the braces with the chord, while the values  $y_j$ ,  $y_i$  are the effective lengths of welds connecting the braces to the rib plate.

The effective lengths of welds depend on the susceptibility of the connected member walls. Welds are loaded with components of forces occurring in braces parallel and perpendicular to the plane of the chord and the rib. Stresses in welds  $\sigma'$  and  $\sigma''$  are calculated taking into account the load direction, parallel or perpendicular to cross-section of the weld.

## 2. Description of the K-type CHS joint with the rib plate FEM analysis

### 2.1. Assumptions adopted for the joint analysis

The intermediate K-type joint with the rib plate made of circular hollow sections was analyzed. In order to obtain different angles of braces inclination, the lattice girder with the same span of 12.0 m was varied in terms of heights,

which were successively 1.70 m, 1.40 m and 1.10 m. Corresponding angles of braces inclination to the bottom chord were  $60^\circ$ ,  $54^\circ$ ,  $48^\circ$ . The truss was loaded with concentrated forces from the standard loads (dead, snow, wind loads) in the joints of the top chord. As the sections of the top and bottom chord, circular hollow sections RO 88,9 $\times$ 5 mm were assumed, while as the braces RO 57 $\times$ 4 mm. The thickness of the rib plate was taken equal to 5 mm. The girder schema for variant I is shown in Fig. 6. The joint adopted for analysis is marked with the letter "A". The joint model, which was used for the FEM analysis is shown in Fig. 7.

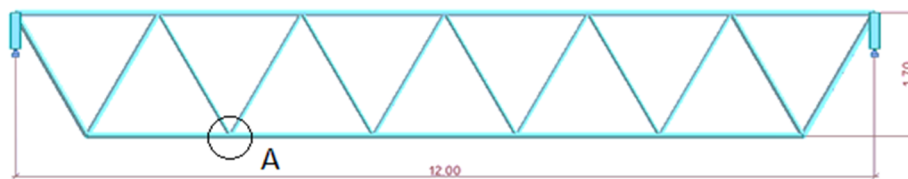

Fig. 6. Analyzed truss and the designation of the analyzed joint

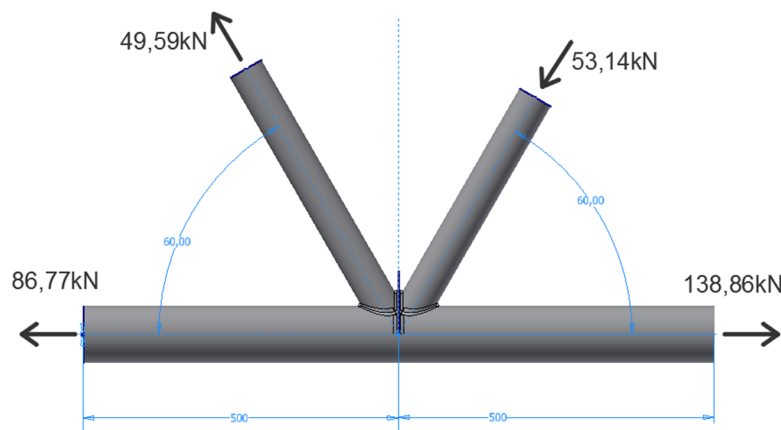

Fig. 7. Analyzed joint modeled in the FEM analysis program

The same material parameters were adopted for each joint. Both truss chords, braces, ribs and welds were modeled from S235 steel, which has a yield strength of 235 MPa and Young's modulus of 210 000 MPa. The material was defined as Bilinear Isotropic Hardening”

The mesh density of the analyzed joint was 5 mm, while in order to achieve more accurate results, the mesh was thickened around to 2 mm near the welds. In order to facilitate computer analysis, three solids of welds were modeled which were not connected to each other. At the same time, their length is as large as possible.

Additionally, in order to obtain a more accurate image of stresses not only outside the joint, but also inside it, it was decided to cut the joint along the axis of symmetry of the bottom chord, in the plane of the truss. The model of the joint together with the mesh of finite elements and the solids of the welds is shown in Fig. 8. The main object of the analysis was the weld connecting the brace with the bottom chord. In addition to the three height variants of the truss, each joint was modeled with three variants of weld thickness successively: 4 mm, 3 mm, 2 mm. In the model connections between the bottom chord and braces and the rib was defined as sliding with a coefficient of friction of 0.15, while the remaining connections, between welds and individual elements, were defined as bonded.

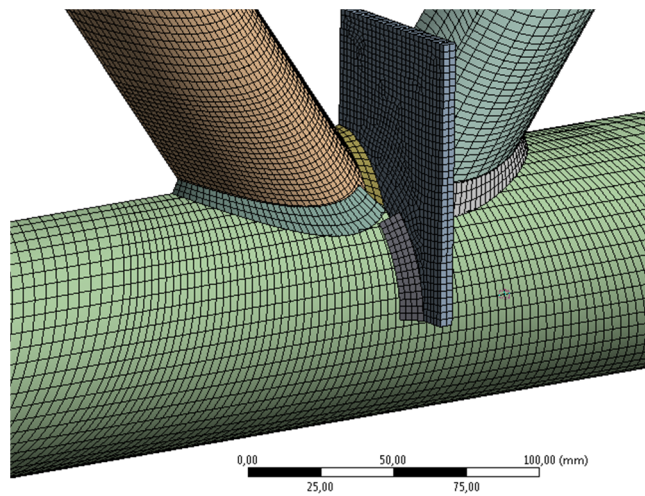

Fig. 8. View of the meshed joint with the welds

Computer analysis was carried out in a program using FEM type analysis. After the joints modeling, they were loaded with concentrated forces occurring in a given truss joint. In the figures below (Fig. 9 to 14) the results of von Mises

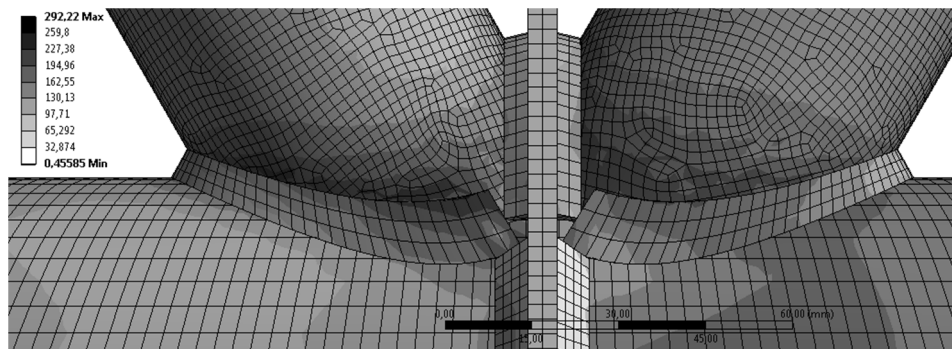

Fig. 9. Stress in the joint for the angle of  $60^\circ$  and welds 4 mm

stresses for the truss of  $60^\circ$  and  $48^\circ$ , as well as for the thickness of welds 4 mm and 2 mm were presented.

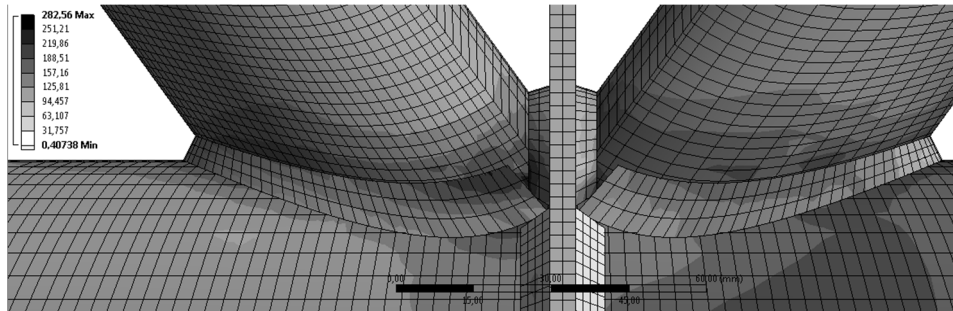

Fig. 10. Stress in the joint for the angle of  $54^\circ$  and welds 4 mm

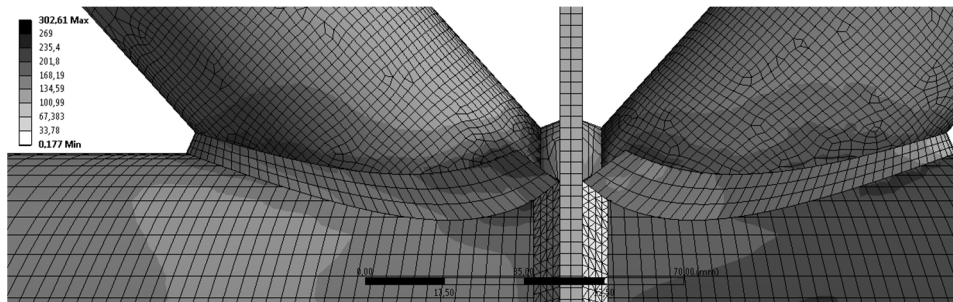

Fig. 11. Stress in the joint for the angle of  $48^\circ$  and welds 4 mm

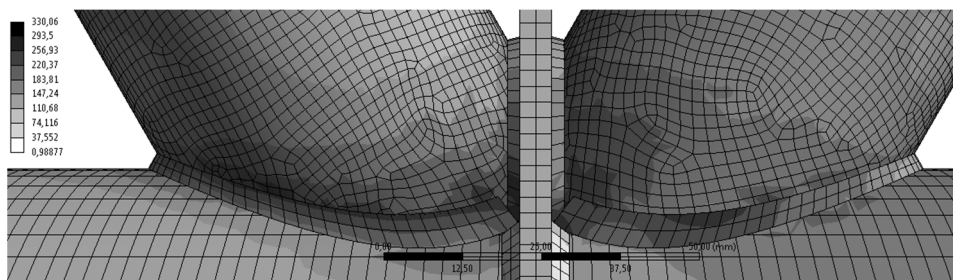

Fig. 12. Stress in the joint for the angle of  $60^\circ$  and welds 2 mm

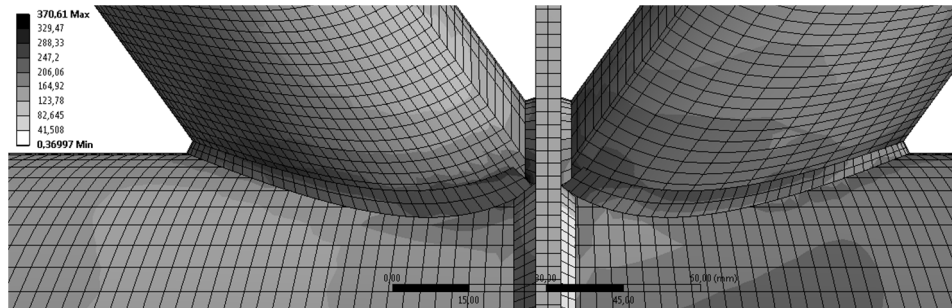

Fig. 13. Stress in the joint for the angle of  $54^\circ$  and welds 2 mm

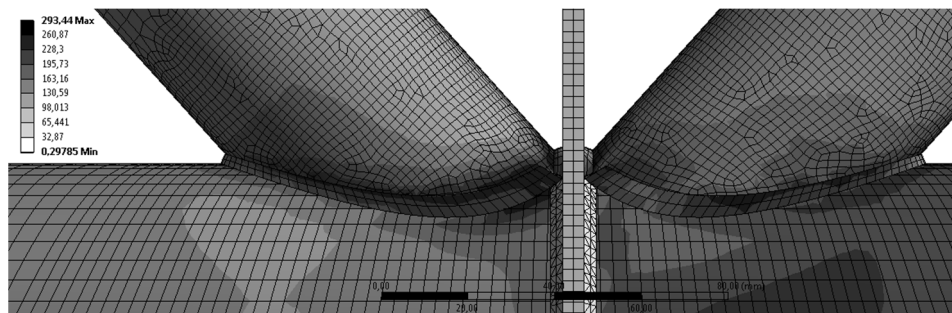

Fig. 14. Stress in the joints for the angle of  $48^\circ$  and welds 2 mm

### 3. Conclusions

After analyzing the test results, it can be concluded that the distribution of stresses in the welds connecting the braces with the chord varies and depends on the angle of inclination of the braces in relation to the chord and the thickness of the weld. In the case of an angle  $\theta_i \leq 60^\circ$ , the greatest stresses in the welds connecting the brace with the chord can be observed in the groove weld located on the side of the obtuse angle, near the place of the rib plate. Stress values decrease in the longitudinal weld together with the distance from the rib plate, in order to reach its minimum on the opposite side of the brace, i.e. in the transverse weld on the side of the acute angle. A smaller variation in the stress values in both transverse joints occurs in the case of angle  $\theta_i \leq 48^\circ$ . The transverse weld located on the side of the acute angle more effectively transfers stresses from the brace to the chord.

This is especially evident in the case of welds with a thickness of 2 mm because a greater role in the transfer of stresses play horizontal welds connecting the brace with the chord. Increasing the thickness of welds to 4 mm disturbs slightly the described stress distribution in the welds, causing that the greater part of the transferred force falls on the vertical welds connecting the brace with the rib.

If the brace is compressed, it can be observed that the maximum stresses in the longitudinal welds are shifted towards its central part. However in the case of tension brace the largest stresses can be observed in close proximity to the rib plate.

These analyses indicate that not all welds joining the brace members to the chords carry the load in the same way. On the basis of computer analyzes it is impossible to determine exactly which sections of welds are fully effective and which transfer only a small load. This is especially difficult in the case of longitudinal welds. However, the calculations indicate that the standard assessment of stresses in welds of hollow section joints is only approximate and does not fully reflect the actual distribution of stresses in the welds, which confirms the earlier studies of Packer and Henderson. To verify these calculations, experimental tests should be carried out on real truss joints. However, the analysis will confirm that the recommendations given in the literature regarding the calculation of welds' resistance can be optimized and new computational solutions can be introduced, which however, are impossible to propose at the current stage of research.

## References

- [1] Bródka J. Design of joints with the rib plate made of hollow sections. Capacity of joints. II International Polish-Ukrainian Scientific-Technical Conference "Current Problems of Metal Structures". Book of the Conference. Gdansk, 27-28 November 2014 (in polish).
- [2] EN 1993-1-8: 2008 Eurokod 3: Design of steel structures - Part 1-8: Designing of joints.
- [3] Packer J. A., Henderson J. E.: Hollow Structural Section Connections and Trusses – A Design Guide. Second Edition. Canadian Institute of Steel Construction. Toronto 1997.
- [4] Bródka J., Broniewicz M.: Steel structures made of hollow sections. Vol. 1. PWT. Rzeszów 2017 (in polish).
- [5] Bródka J., Broniewicz M.: Calculation of welded joints of trusses made of rectangular hollow sections. – Steel Structures, 2002, No 4 (in polish).
- [6] Bródka J., Broniewicz M.: Assessment of the welded joint resistance according to EN 1993-1-8: 2009. – Steel Structure, 2007, No 1 (in polish).
- [7] Bródka J., Broniewicz M.: Calculation of welding trusses overlap joints made of rectangular hollow sections. – Archives of Civil Engineering, 2013, No 4.
- [8] ENV 1993-1-1. Eurocode 3: Design of steel structures. Part 1-1. General rules and rules for buildings. Annex K. Hollow section lattice girder connections. CEN. Brussels. 1994.
- [9] Bródka J., Broniewicz M.: Hollow section overlap joints with reinforcing rib plate in structural applications. Lambert Academic Publishing. 2016.

*Przesłano do redakcji: 25.04.2018 r.*

*Przyjęto do druku: 15.06.2018 r.*