

Grzegorz GREMZA¹
Jan ZAMOROWSKI²

DAMAGE ANALYSIS OF THE BLADE TO THE ROTOR HUB CONNECTION IN THE WIND TURBINE

The paper analyzes possible causes of bolts fracture in the connection of the blade to the hub of the wind turbine rotor. This failure has been growth shortly after the wind turbine was started, a few days after the storm. During the storm, electric power was turned off in the whole surrounding area for many hours, therefore it was impossible to control the device. After an initial analysis of failure modes in other wind turbines, it was found, that the bolts failure in the analysed case may be regarded as quite rare. Due to the fact that a significant part of bolts was broken brittle (flat fracture surfaces and lack of permanent elongation), it was decided to analyse the structure of the material in the direction of stress corrosion and hydrogen embrittlement. Among others, microscope analysis of fracture surfaces after their proper cleaning from corrosion products was carried out. The broken bolts were made as undersized, what is mainly used in fasteners intended for hot-dip galvanizing. On the basis of the purchase documentation analysis, it was presumed that the bolts were not galvanized by their manufacturer, which is obliged to perform the routine inspection in production process preventing the introduction of the hydrogenated bolts into the market. Besides the bolts examination, the scenarios of connection loads in extreme situations, in particular the impact of wind with high energy in the most unfavourable direction relative to the blade and nacelle, as well as the force resulting from the impact of the rotating blade on the tower that preceded the collapse of the whole structure, were considered. Conclusions from the performed tests and calculations by use of two calculation models of the connection were presented.

Keywords: undersized bolts, mechanical properties of bolts, wind turbine, blade failure, model of joint

1. Introduction

In recent years, reuse of second-hand structures of wind turbines in Poland has become frequent. In these turbines, failures consisting in the loss or failure of blade fragments due to progressive fatigue process or production defects [1] as well as excessive rotor speed, are quite common. Less common is a detachment of

¹ Corresponding author: Grzegorz Gremza, Silesian University of Technology in Gliwice, Department of Building Structures, ul. Akademicka 5, 44-100 Gliwice; tel. 322372224; ggremza@interia.pl

² Jan Zamorowski, University of Bielsko-Biala, Faculty of Materials, Civil and Environmental Engineering, ul. Willowa 2, 35-959 Bielsko-Biala; zamski@interia.pl

blade from the rotor or the entire rotor from the nacelle due to the failure of bolted connections. This paper discusses the case of the bolted connection between blade and hub, which failure was accompanied by the collapse of the tower of a typical wind power plant. The power plant consisted of a steel tower, a nacelle and a 58 m in diameter rotor with an axis at 71 m above the ground (Fig. 1a).

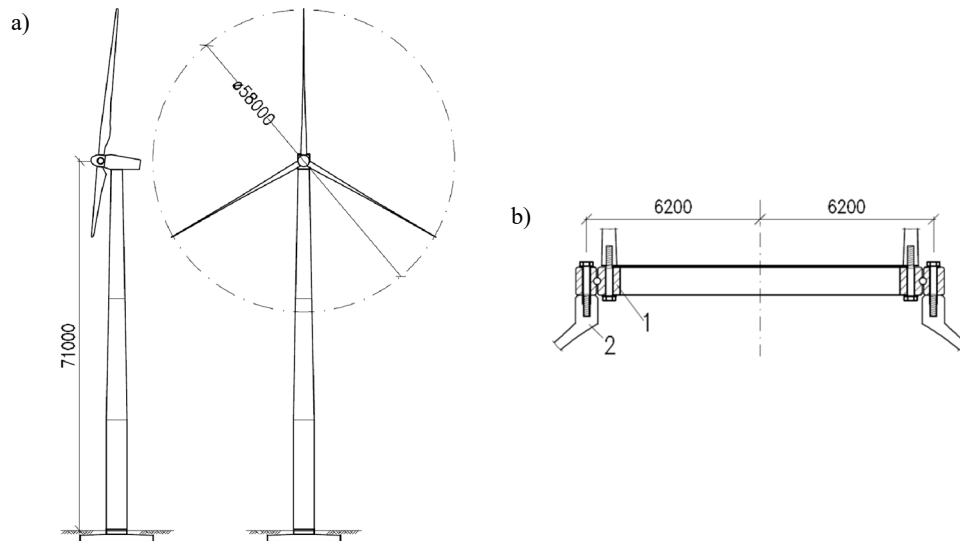

Fig. 1. Wind turbine: a) general view, b) joint between blade and hub, 1–bearing, 2–hub

2. Joint between blade and hub

In the connection of the blade to the hub four-point contact bearings, bolted on one side to the hub and on the other side of the blade, were used (Fig. 1b). The hub was made of nodular cast iron in a spherical form and fixed to the main shaft bearing. In the hub, threaded holes were made and in the blade, threading inserts were placed. To connect the bearing to the hub, 52 bolts M24 class 10.9 with the mark W of the manufacturer and with the additional marking U (10.9U) i.e. with undersized thread were used (Fig. 2). Such a thread is sometimes executed to maintain the required minimum clearance for the threaded connection after applying a thick layer of zinc coating in the hot dip galvanizing process.

As a result of undersize threading, the effective cross-section of the bolt decreases slightly. Moreover, bolts with an undersized thread should not be combined with nuts with oversized thread. In a given case it is difficult to prove whether the thread in the threaded hole was oversized. On the other hand, it was much longer than a thread in a typical nut, which should compensate for its likely weakening due to oversizing. In the connection of bearings to the blade, bolt class 10.9 with normal clearance and probably made by another manufacturer were used. Only 10.9U bolts in the connection of the bearing to the hub have been destroyed.



Fig. 2. Bolts in analysed joint: 1–old bolt, 2–new bolt bought in Poland

An important issue related to hot-dip galvanizing is the hydrogen embrittlement of bolts class 10.9. Regardless of the method of threading, these bolts must be galvanized under the manufacturer's control and tested in a proper way for hydrogen embrittlement at the production stage. During the in-situ inspection, it was found that the M24 bolts class 10.9, that was used in a bearing-to-hub connection of the blade detached during the disaster, were galvanized, while on the invoice there is a marking of these bolts "Bolt M24x180 DIN 931 class 10.9 g. 70 ", without any information on the coating of these bolts with a zinc coating. The certificate also does not contain any information about galvanizing these bolts. Therefore it can be assumed that these bolts were galvanized outside the bolt factory.

3. Wind turbine damage

The disaster was preceded by a period of a few days strong winds, during which the wind turbine was at least twice immobilized: for the first time automatically due to exceeding the permissible wind speed and for the second time due to lack of power supply. A few minutes after it was restarted, disaster has occurred. One of the blades crashed into the tower causing its brake-down (Fig. 3), what was observed by the windmill owner. This blade was detached from the rotor and discarded (thrown) far away from the windmill. During the in-situ inspection, it was found, that this blade's shells have been stripped off (Fig. 4a) and its supporting beam (spar) has been partly broken at the point of impact on the tower. A view on a bearing devoid of broken bolts has been shown in Fig 4b.

The thesis was made that the following causes of the disaster could have been:

- failure of the blade to the hub connection due to plasticization of a part of bolts or the brittle fracture of the remaining bolts,
- detaching the shells of the blade from its supporting beam and blocking of the blade's movement at the level of approximately + 52.7 m; this possibility is indicated by the damage of the blade and the tower occurring at this level,
- a collapse of the tower due to its kinking in the section with the most used bearing capacity.

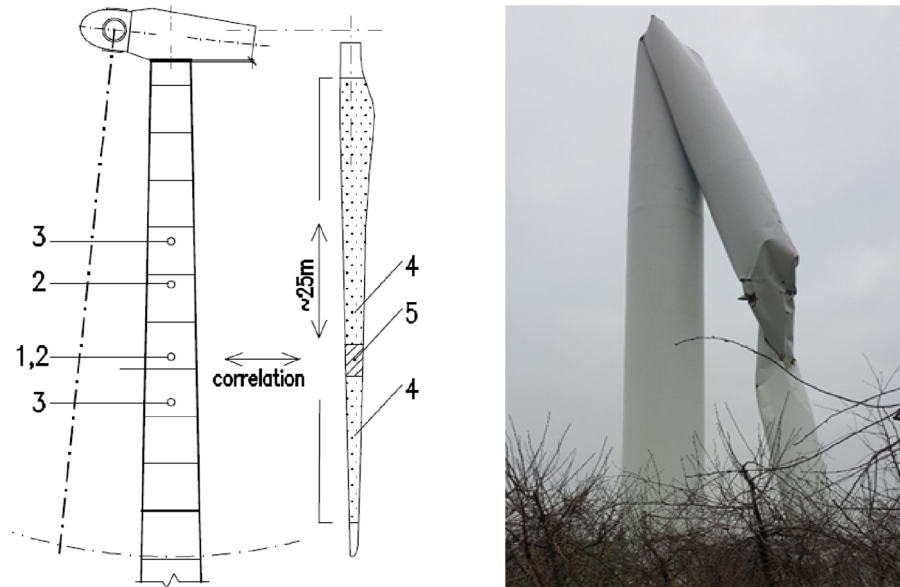

Fig. 3. Wind turbine damage: 1–point of the blade impact, 2–ends of twisted section, 3–ends of braking, 4–area of a blade without shells, 5–broken section of a blade

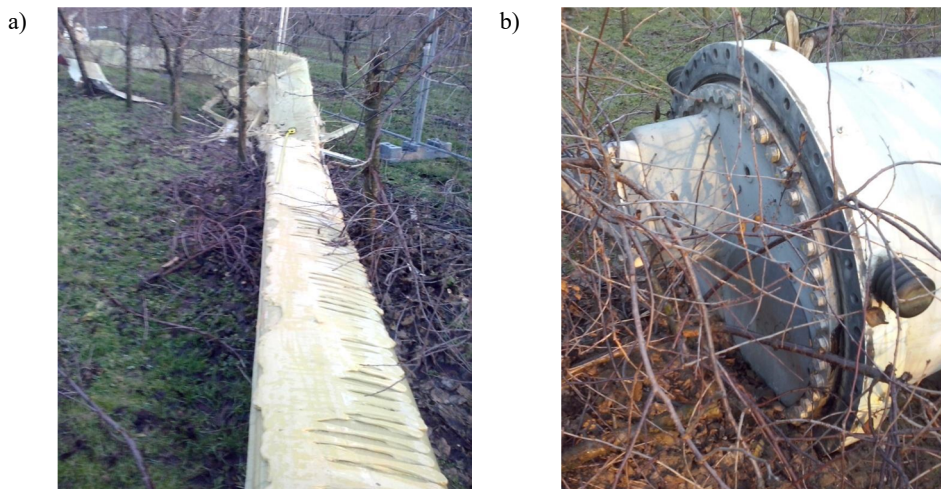

Fig. 4. Detached blade: a) supporting beam without shells, b) bearing without bolts

The shaft of the tower in the level of the blade's impact has been twisted, which may indicate a hit as a factor initiating its collapse. On the basis of calculations, the tower collapse due to its insufficient load capacity was excluded. The tower was calculated assuming that the level of its quality declared in the documentation was preserved. It was decided to carry out a wide-spread analysis of the whole structure as well as possible problems in the connection.

4. Bolts failures

The immediate cause of the failure of the blade-to-rotor connection was a fracture of bolts, what is rare in wind turbine failures. During the inspection it was found, that some of the bolts at about 1/3 of the circumference of the joint were destroyed with very small elongation or brittle (Fig. 5).

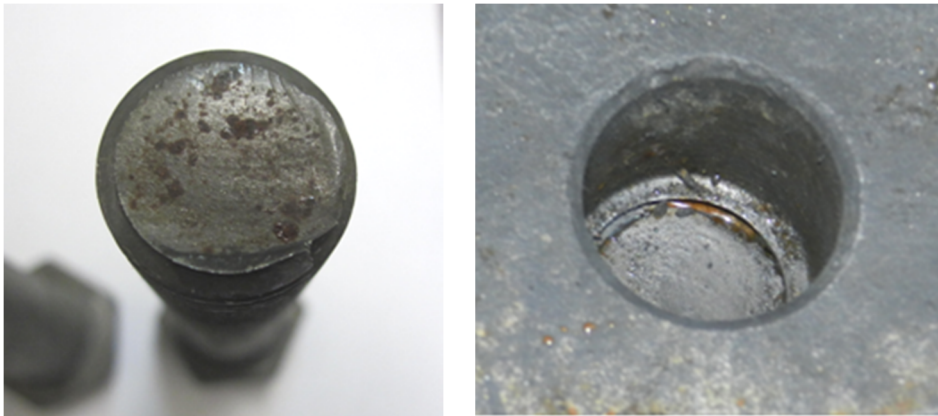

Fig. 5. The brittle fracture surface of bolt and a hole with end of bolt

The remaining bolts on about 2/3 of the circumference of the joint were destroyed plastically, some of them with very visible elongation and necking, which were estimated at up to 20%. The fracture surfaces of a part of bolts indicated a brittle fracture.

5. Bolts testing

5.1. Hydrogen content measurements

Bolt material was qualified as a ferritic steel. Steels of this type in bolts class 10.9 are a material that is susceptible to the adverse effects induced by possible introducing of hydrogen. For this reason, one of the bolts, with brittle fracture surface, has been examined for hydrogen content. It was obtained a hydrogen content of 7 ppm for the bolt in the condition with the coating, and after removing the coating – 1.5 ppm. The examined bolt has been used in the connection since 2015.

Atomic hydrogen can be introduced into the metal during the galvanizing process or during contact with the atmosphere due to the creation of an electric cell in a moist connection. In a case when hydrogen would get into the bolt in the hot-dip galvanizing process, the bolt usually undergoes a brittle failure in the first twenty-four hours. On the other hand, if the brittle fracture of the bolt would appear after a longer period of its exploitation, it could mean that hydrogen was

introduced into the bolt from the environment in which the bolt worked, which can also be proved by the much higher hydrogen content on the surface of the zinc coating (7 ppm) compared to the hydrogen content under the zinc coating. Hydrogen content of 1.5 ppm on the surface of the steel could not be the cause of its brittle fracture immediately before or during the disaster.

5.2. Analysis of fracture surfaces

The fracture surfaces of three selected bolts were examined. Tests confirmed macroscopic observations regarding the manner of their destruction. The fracture in bolt '1' was characterized with a ductile morphology with characteristic cavities (dimples) typical of this type of fracture (Fig 6a).

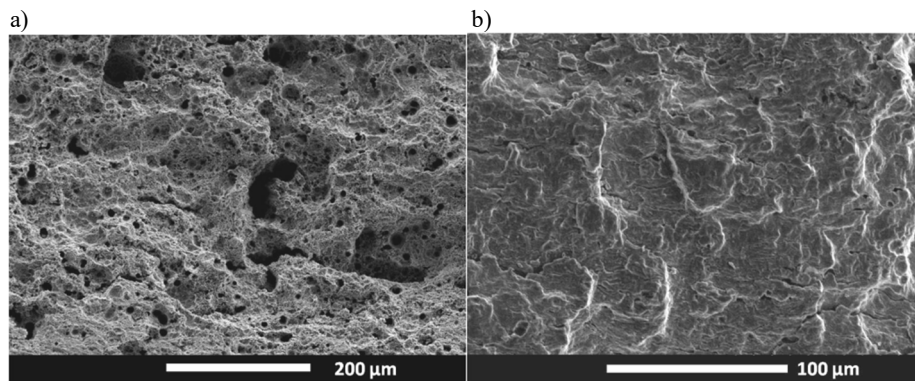

Fig. 6. Fracture surfaces of bolts: a) ductile of bolt 1, b) brittle of bolt 3

Such a fracture testifies destruction of the material after exceeding the yield point. The fracture of bolt 3 was mainly brittle (Fig. 6b) and the fracture of bolt 2 was mixed (both brittle and ductile).

Almost over the whole surface of the fracture of bolt 3, characteristic lines resembling fatigue beach marks are visible (Fig 7a). The areas between these lines are brittle. The appearance of the fracture suggests that the material was destroyed gradually, e.g. during alternating bending of the bolt. On the fragment of the fracture of the bolt 2, near its surface, characteristic lines indicating the fatigue cracking are also visible (Fig. 7b). Such a character of the fracture, at the surface, can occur not only as a result of alternating bending of the bolt but also in the case of hydrogen-induced cracking.

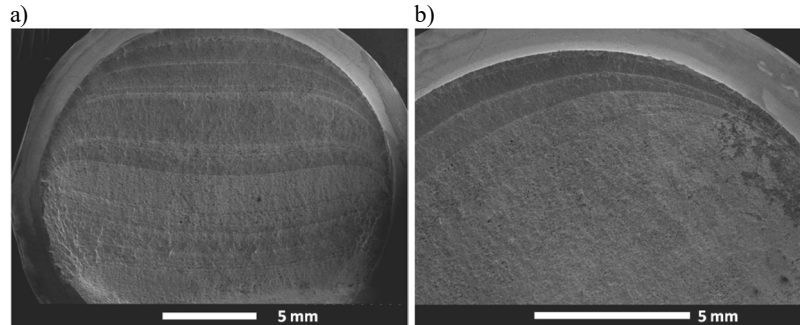

Fig. 7. Fracture surfaces of bolts: a) bolt 3, b) bolt 2

Theoretically, there should be no significant stress amplitudes in a preloaded bolt, what is reflected in the recommendation given in standard [2] allowing to adopt a reduced range of stress fluctuating for such a bolt. The brittle fracture of the bolt material characterized with symmetrical fatigue beach marks (beach lines) relative to the axis passing through the centre of the cross-section (see Fig. 7a) may indicate an alternate bending of the bolt after a separation was created in the connection of the blade with the rotor. Therefore, the hypothesis may be put forward, that the bolts in the tensioned zone had broken up first. Then, in partly damaged joint an alternate bending of bolts in compression zone and as a result their fatigue failure occurred.

5.3. Tensile tests of bolts

Two specimens of $\varnothing 10$ in diameters with a gauge length equal to its five diameters, taken from bolts used to assemble the structure, were tested. Tensile strength (R_m) of 954 MPa and 962 MPa, as well as the yield stress ($R_{p,0.2}$) 815 MPa and 860 MPa and elongation from 15.2% to 15.8% were obtained. The strength of the bolt material was slightly smaller than declared and corresponded to the theoretical class 9.9. However, this strength was sufficient to transfer all design loads.

6. Joint modelling

6.1. Simple linear-elastic model

In the connection of the blade with the hub (Fig. 8a), a linear distribution of deformations was assumed, as in the structural members subjected to alternate actions [3]. It was assumed that the load in the compression zone is transferred by a pressure of a ring of bearing on the hub, and in the tension zone – by the bolts tension. In this model, a pressure of the ring on the hub caused by preloaded bolts is not taken into account. The effective section was determined, in which the bolts transmit tension and the flange transfers pressure (Fig. 8b). In the calculation of the connection characteristics, the nominal cross-section of the bolt has been adopted.

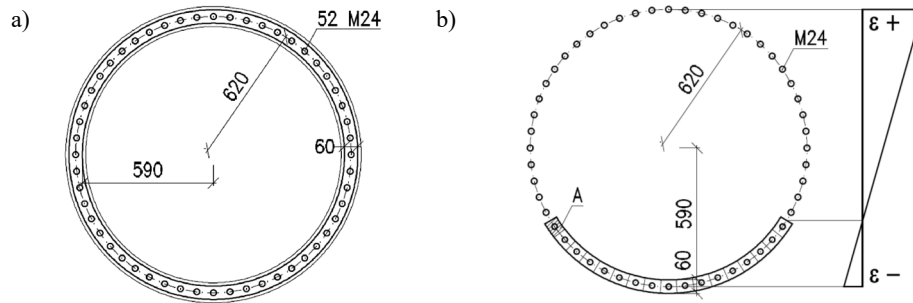

Fig. 8. Connection: a) view, b) scheme of calculation (effective cross-section)

6.2. Mechanical model

The connection of the rotors' blade to the hub was calculated using a mechanical model consisted of 52 basic components of the joint. The number of these components corresponds to the number of bolts. Each component was modelled as a spring (Fig. 9), whose axis coincided with the bolt axis, both in tension and compression zone. The stiffness of the spring in the compression zone was estimated based on the elastic shortening of the pre-compressed part of the ring (bearing race) and the hub with a length corresponding to 1/52 of the connection perimeter and a thickness of 15 cm – see Fig. 9. In the calculations, Young's modulus $E = 210$ GPa and the pressure area of the ring for the hub $A = 39.5$ cm² (see fig. 8b) were adopted. The stiffness of the spring $k_c = EA/l = 5\,530$ kN/mm was obtained, where $l = 150$ mm is an effective length of the spring – see fig. 9.

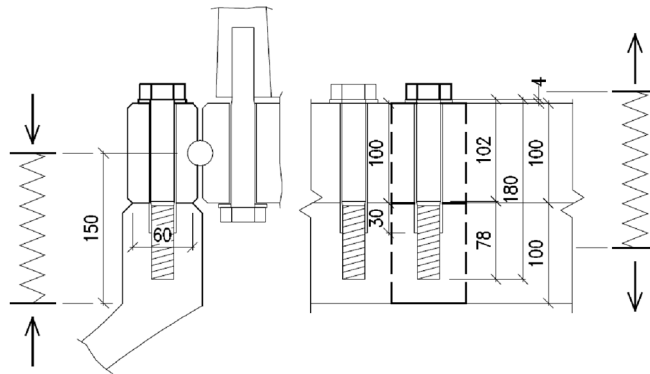

Fig. 9. Fragment of the joint and its modeling as springs in compression and tension zones

The elastic elongation of the not-tightened bolt was described by formula [4]:

$$\delta_y = \frac{F_y}{E} \left(\frac{0,4k + l_s}{A} + \frac{l_g - l_s}{0,5(A + A_s)} + \frac{l_t + 0,6 \text{ m}}{A_s} \right) \quad (1)$$

Elongation of the preloaded bolt in the ultimate limit state depends significantly on its dimensions. In the bolts class 10.9, at the moment of their fracture, the shank deformation of the section without thread is still elastic. According to [4], the formula was adopted:

$$\delta_y = \frac{F_u}{E} \left(\frac{0,4k + l_s}{A} + \frac{l_g - l_s}{0,5(A + A_s)} + \frac{F_u}{E} \cdot \frac{l_t + 0,6 \text{ m}}{A_s} + \frac{F_u - F_y}{\alpha E} \cdot \frac{l_t + 0,6 \text{ m}}{A_s} \right) \quad (2)$$

In formulas (1) and (2): A – the gross cross-section area, A_s – the tensile stress area, k and m – head and nut height, l_s – length of unthreaded shank (body length), $l_g - l_s$ – transition, l_t – thread length from the transition to the beginning of the nut, α – coefficient equal to 0.013 for class 10.9 bolts, E – Young's modulus, $F_y = A_s f_{yb}$, $F_u = A_s f_{ub}$.

The extension spring characteristic in the tension zone of the connection was determined under the following assumptions:

- until the separation is created, at the force equal to the preloading force magnitude $F_{p,c} = 0.7 f_{ub} A_s = 247.1$ kN according to [5], the stiffness of parts in the tension zone is equal to the parts stiffness in the compression zone,
- ultimate elongation of the basic component of the joint is obtained by subtracting from the total elongation of the bolt defined by the formula (2) the part of its elastic elongation which was utilized during its tightening (0.473 mm) and adding the value resulting from the reducing the contact pressure between the ring and the cooperating hub fragment (0.045 mm); such assumption results from relaxation of the rigid ring under external force without essential increase of the force in the bolt – see e.g. [6–8].

The obtained characteristic of the basic part of the joint in the tension zone is shown in Figure 10b.

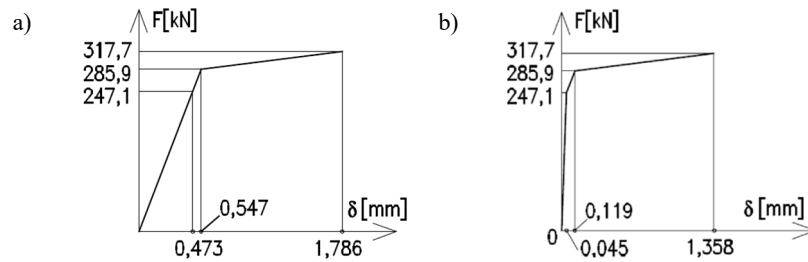

Fig. 10. Force – displacement characteristics: a) for bolt M24 class 10.9, with the actual length of its shaft and its threaded part b) for the basic component in tension in the pre-stressed connection

The bending moment in the connection was applied in the centre of gravity of the ring using fictitious finite elements with a high stiffness, connected to the basic parts.

The simple mechanical model described above could be used because there was no prying effect in the connection under consideration, and, except bolts, there was no plasticization of other parts, what was considered e.g. in [9–10].

7. Loads acting on the connection and the bolts effort

7.1. Extreme wind load

The calculations were made for the most unfavourable blade position in relation to the wind direction. Force coefficients were adopted on the basis of the data included in many publications. Due to the fact that wind turbines are automatically turned off during extreme wind, it was taken into account in the calculations, that during such wind the blades do not rotate. The estimated with this assumption bending moment in the connection of the blade to the hub will not exceed 1 423 kNm for the standard wind. In the days preceding the disaster, the speed of the wind was close to the standard wind speed, and on the day of the disaster these speed during gusts reached up to 15 m/s.

7.2. Load caused by the blade collision with the tower

Adopting the highest operational rotational speed of the rotor $\Omega = 30.8$ rpm, the velocity at the point of the centre of gravity of the blade $V = 25.65$ m/s has been obtained. It was assumed that the two upper blades stop as a result of blocking the movement by the third lower one, which acts as a brake together with the tower (similarly to a bump post e.g. in crane girders). The upper two blades (Fig. 11a) act on the axis of the system with the horizontal force F_{hub} and the moment M_{hub} :

$$M_{hub} = 2Fb, F_{hub} = 2F\cos\alpha \quad (3)$$

where: α – angle of inclination of the blade to the vertical axis (60 degrees), b – distance of the centre of gravity of the blade from the axis of the hub. The force and the moment will be taken by the system consisted of the tower and the third blade that had collided with the tower. The formula based on the blade's kinetic energy is as follows:

$$0,5mV^2 = Fs \quad (4)$$

where s – distance that was made by the upper blade in period of time from the lower blade collision with the tower to the stop of the rotary motion inclusive the elastic movement of the tower and the blade itself, m – blade mass applied in its center of gravity, F – inertia force acting on the blade.

Adopting the above assumptions and calculating necessary stiffness coefficients, the bending moment in the connection of the lower (blocked) blade to the hub equal to 5 949 kNm was obtained. (Detailed formulas allowing the calculation of the bending moment in the connection together with their derivation will be presented in a separate publication.)

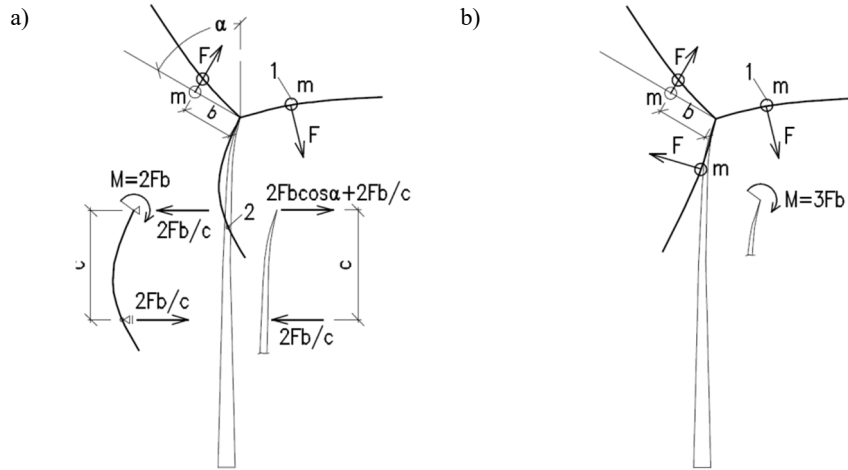

Fig. 11. Schemes of a structure work: a) blade collision with the tower, b) sudden shaft locking

7.3. Load caused by sudden shaft locking

The shaft locking may have occurred in a case of damage of pitch mechanism. During the disaster, one of the elements of this mechanism was broken. This could have preceded the disaster or occurred as a result of this disaster.

Similarly to the point 7.3. the greatest operational rotational speed of the rotor 30.8 rpm was adopted. It was assumed that the rotor at the moment of its sudden blockage acts on the tower with a moment (Fig. 11b):

$$M_{hub} = 3Fb \quad (5)$$

and the kinetic energy of one blade is defined by (4) – see point 7.2. Taking into account the rotation and displacement of the top of the tower resulting from the action of the concentrated moment at the hub level and taking into account the susceptibility of the blade to bending, at the root of the blade the moment 5 763 kNm was obtained.

7.4. The effort of the bolts depending on calculation model

Table 1 presents the estimated values of bending moments acting in the connection of the blade to the rotor hub and the values of forces in the bolts, obtained using the models described in point. 6.1 and 6.2. The obtained results in the ultimate limit state, after the separation between the ring and the hub occurred, are very similar in both models. Using the connection model described in point 6.1, the highest value of external screw load from wind load is 66.5 kN, and according to the model described in point. 6.2–88.3 kN. These values are much smaller than the preloading force in the M24 bolt 10.9.

Table 1. Values of tension external forces per bolt

Bending moment [kNm]	External tension force per bolt [kN]		Load case
	Simple model point 6.1	Numerical model point 6.2	
1 423	66.5	88.1	Design values of wind load (point 7.1)
152	7.1	9.4	Wind load at speed 15 m/s
5 949	278.3	277.2	Blockage of the blade after collision (p. 7.2)
5 763	269.5	272.9	Shaft blockage (point 7.3)
The characteristic resistance of the M24-10.9 bolt with a normal thread acc. EN 1993-1-8 is 317.7 kN; the design resistance according to PN-B-03200 is 239.0 kN, and according to EN 1993-1-8 – 254.2 kN. Considering that the thread was undersized and that the tensile strength of the bolts was at a level $R_m = 955$ MPa it was obtained $F_{t,Rk} = 285$ kN			

In the case of the load resulting from the blockage of the movement of the blades, bolts fracture would be potentially possible, because the forces acting on them would be slightly larger than their design resistances calculated in accordance with the standards.

8. Conclusion

The obtained results of calculation and material tests indicate that the direct cause of damage the connection of the blade to the rotor hub could have been caused by the fracture of bolts in the tensile zone due to the impact of the blade on the tower. During the windmill reassembling in Poland in 2015, there is a high probability that one of the rotor blades manufactured around 2003, was installed in the windmill that has been produced in 2008. A situation occurred, in which shells have been stripped away from the spar practically for the whole length of that blade. Resultantly the rotor movement was blocked and the connection of blade to the rotor has been broken. As a result, the tower has collapsed.

In the connection of the blade to the rotor the undersized high strength bolts, likely galvanised outside the bolt factory, were used. The strength of these bolts was slightly lower in comparison to the nominal strength. The bolts were tightened with the torque moment indicated in the technical documentation of the windmill, without carrying out own tests applying the adopted method of their lubricating. Therefore, the values of the tightening forces introduced into the connection are not known.

The presence on the market of fasteners with mechanical properties deviating from nominal values, low awareness of sellers and technical staff regarding the consequences of using high-strength galvanized bolts outside the bolt factory as well as the principles of correct tightening of high-strength bolts may be worrying.

References

- [1] Myrent N., Adams D. E., Griffith D. T.: Wind turbine blade shear web disbond detection using rotor blade operational sensing and data analysis. Philosophical Transactions A, 2015, <http://rsta.royalsocietypublishing.org/content/373/2035/20140345>.
- [2] PN-EN 1993-1-9. Eurocode 3: Design of steel structures – Part 1-9: Fatigue.
- [3] Rykałuk K.: Konstrukcje stalowe. Kominy wieże maszty, Oficyna Wydawnicza Politechniki Wrocławskiej, Wrocław 2004.
- [4] Steurer A.: Das Tragverhalten und Rotationsvermögen geschraubter Stirnplattenverbindungen, ETH Zürich, 1999 (in German).
- [5] PN-EN 1090-2: Wykonanie konstrukcji stalowych i aluminiowych. Część 2: Wymagania techniczne dotyczące konstrukcji stalowych.
- [6] Łubiński M., Filipowicz A., Żółtowski W.: Konstrukcje metalowe. Część 1. Podstawy projektowania, Arkady, Warszawa 1986.
- [7] Bródka J., Kozłowski A., Ligocki I., Łaguna J., Ślęczka L.: Projektowanie i obliczanie połączeń i węzłów konstrukcji stalowych – tom 1. Polskie Wydawnictwo Techniczne, Rzeszów 2013.
- [8] Kulak G.L., Fisher J.W., Struik J.H.A.: Guide to Design Criteria for Bolted and Riveted Joints, American Institute of Steel Construction, Chicago 2001.
- [9] Leń D., Ślęczka L.: Efekt dźwigni w śrubowych połączeniach kołnierзовych kształtowników zamkniętych okrągłych, Konstrukcje Betonowe i Metalowe, Wyd. Uczelniane Uniwersytetu Technologiczno-Przyrodniczego w Bydgoszczy, Bydgoszcz 2015, str. 223–230.
- [10] Wojnar A., Kozłowski A.: Sztywność i nośność śrubowych połączeń kołnierзовych rur dużych średnic, Zeszyty Naukowe Politechniki Rzeszowskiej, z. 50 (256), Rzeszów 2008, str. 299–311.

Przesłano do redakcji: 12.04.2018 r.

Przyjęto do druku: 15.06.2018 r.