

Mariusz MAŚLAK<sup>1</sup>  
Maciej SUCHODOŁA<sup>2</sup>  
Piotr WOŹNICZKA<sup>3</sup>

## TEMPERATURE DISTRIBUTION IN A STEEL BEAM-TO-COLUMN JOINT WHEN EXPOSED TO FIRE. PART 1: END-PLATE JOINT

Temperature distribution usually observed in steel beam-to-column end-plate joint after 15 minutes of its standard fire exposure is presented and discussed in detail. Two types of joints are analysed for comparative purposes. The first one is a pure steel connection while the other is covered by a reinforced concrete slab. Numerical simulation of the considered joint heating scenario was performed using the 3D model in the ANSYS environment. Some results were additionally verified by simpler calculations carried out on 2D models using the SAFIR computer program. It is emphasized that due to the local accumulation of many massive steel plates the representative temperature values identified in particular joint components are significantly lower than those which at the same time are measured in beam and column outside the connection. This means that the classic assumption of even temperature over the entire length of all the structural elements of a frame load-bearing structure exposed to fire at any time during such fire, without distinguishing in the formal model any cooler nodal elements, is always safe but very conservative. In addition, as the fire develops the differentiation between the temperature values relating to the beam web and to the beam flanges becomes more visible. This effect is particularly significant in the presence of a massive floor slab adjacent the upper flange of a frame I-beam which effectively cools it.

**Keywords:** beam-to-column steel end-plate joint, fire, temperature distribution, joint components, numerical simulation

---

<sup>1</sup> Corresponding author: Mariusz Maślak, Cracow University of Technology, Faculty of Civil Engineering, Chair on Metal Structures, Warszawska 24, 31-155 Cracow, phone: 126282033, e-mail: mmaslak@pk.edu.pl

<sup>2</sup> Maciej Suchodoła, Cracow University of Technology, Faculty of Civil Engineering, Chair on Metal Structures, Warszawska 24, 31-155 Cracow, phone: 126282033, e-mail: maciek.krakow@interia.pl

<sup>3</sup> Piotr Woźniczka, Cracow University of Technology, Faculty of Civil Engineering, Chair on Metal Structures, Warszawska 24, 31-155 Cracow, phone: 126282033, e-mail: pwozniczka@pk.edu.pl

## 1. Introduction

In conventional structural analysis relating to a steel frame load-bearing structure when exposed to fire it is usually assumed that at any moment of such fire the temperature in each member is aligned not only on its entire length but also in any chosen cross-section. The basic advantage of this type of a computational model is its simplicity. It is always safe but in general very conservative. In fact, even when the frame I-beam or the frame I-column is heated on all sides in a uniform manner, with the fire development the difference between the temperature of its web and the other relating to its flanges increases. This is an inevitable consequence of the fact that the web is noticeably thinner than the adjacent flanges. The higher value of the web temperature in relation to the corresponding temperature identified at the same time of the fire in the flanges of the same beam in the case of the beam I-section evenly heated on four sides is particularly well visible for the members which are relatively tall and slender. This type of variation is not so big when the member cross-sections are lower and more stocky.

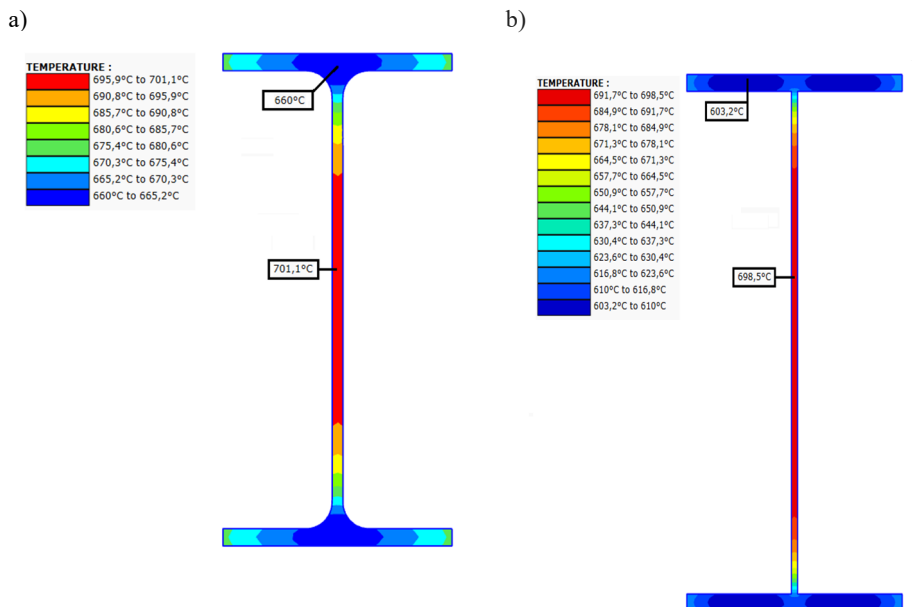

Fig. 1. Temperature distributions in the cross-sections of selected thermally non-insulated steel I-beams, heated on four sides, after 15 minutes of a numerically simulated fire exposure (simulations were performed using the SAFIR computer program [1]). In particular: a) the case of a IPE 330 frame-beam, b) the case of a 576x8x280x18 mm plate girder

It is shown here, in Fig. 1a, that after 15 minutes of a numerically simulated standard heating in a thermally non-insulated IPE 330 beam the representative web temperature turned out to be higher than that identified in the flanges by only about 40 degrees Celsius. If, however, for comparison to verify how in the same fire a relatively slim steel 576×8×280×18 mm plate girder is heated, one can see that after 15 minutes of a fire exposure the difference considered earlier will be closed to 100 degrees Celsius (Fig. 1b). Interestingly, the difference shown in Fig. 1b turns out to be particularly large in the first phase of a fire and then gradually disappears as the temperature of the exhaust gases surrounding the beam increases (Fig. 2).

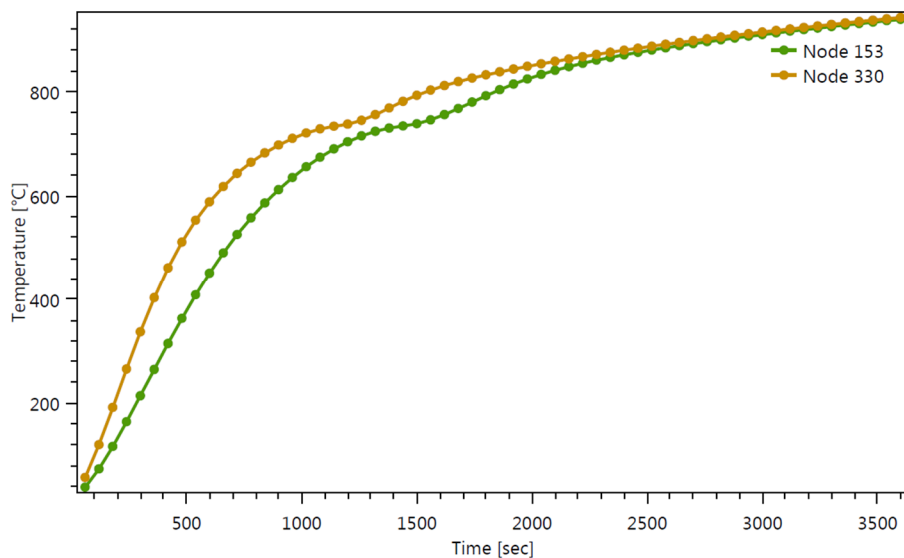

Fig. 2. Dependences between the time of a standard fire exposure and the representative temperature values identified in the I-beam web (higher) and in the same I-beam flanges (lower) for steel 576x8x280x18 mm plate girder, heated on four sides, corresponded to that shown in Fig.1b

In the case when the upper flange of a steel I-beam is adjacent to a massive reinforced concrete floor slab with a large heat capacity, this flange is effectively cooled because the temperature in it and the temperature at the bottom of the slab strive for equalization. Consequently, the beam cross-section is heated only on three sides. Taking into account such a situation requires a significant reduction in the temperature of this upper flange both in relation to the temperature representative for the beam web and to the one representative for the lower flange. Let us note that the difference between the temperature of the beam web and the temperature of the lower flange remains significant, although not so large. Temperature distribution obtained having simulated of a 15 minutes fire exposure in the cross-section of thermally non-insulated steel IPE 330 beam, corresponding to that shown earlier in Fig. 1a but now adjacent to a massive concrete slab, is presented in detail in Fig. 3.

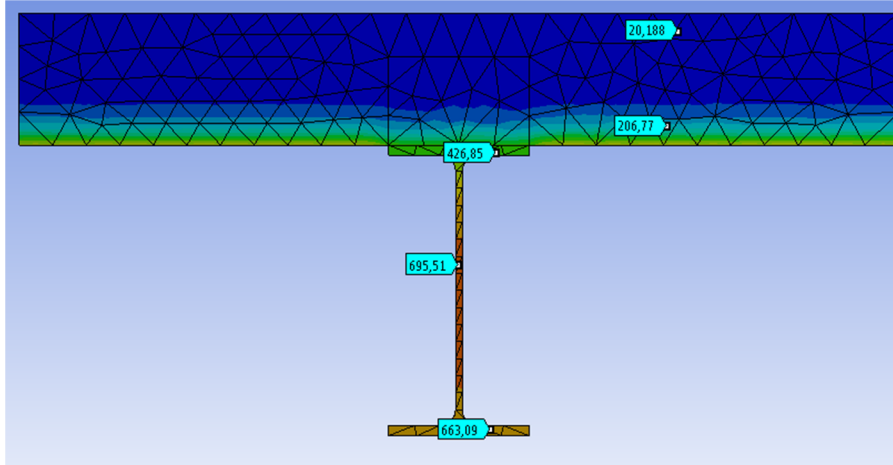

Fig. 3. Temperature distribution obtained after 15 minutes of a standard fire exposure in cross-section of a steel IPE330 frame beam, thermally non-insulated and heated on three sides due to the neighborhood with concrete slab (simulation performed using the ANSYS environment [2])

## 2. Numerical models of the pure steel end-plate joints considered in the analysis

In the introduction to this paper, it was shown that with precise modelling of any pure steel beam-to-column joint behaviour in a fire, the differentiation between the representative temperature of a beam web and the representative temperature values of beam flanges should be taken into account. The primary aim of the authors is, however, to show that the temperature identified in such a joint at any time during a fire due to a very significant increase in the effective steel thickness accumulated here will always be significantly lower than that which at the same time is measured as a representative value for the beam and for the column outside the connection. Therefore, it seems reasonable to consider whether in numerical modelling related to the fire conditions separate from a whole load-bearing frame structure the special nodal elements being colder than the neighbouring elements that they connect. In this chapter the authors want to check which elements of the considered joint are crucial for fire analysis in the sense that the precise determination of their representative temperature values determines both the bearing capacity and the stiffness of this joint under fire conditions. To do this, two steel beam-to-column end-plate joints were precisely modelled in the ANSYS environment [2], connecting a column made of the HEB 180 steel profile and a beam made of the IPE 330 steel profile. All joint components were designed as made of low carbon structural steel S235. The thickness of the end plate in both models was assumed identically, as being equal to 20 mm. The classic bolts with metric thread M20 have also been used. The difference between the joint model shown in Fig. 4a and that of Fig. 4b

consists in adding in the second case two horizontal ribs with a thickness of 10 mm stiffening the column's web. Both models were subjected to uniform heating on all sides, lasting 15 minutes, in accordance with the so-called standard fire scenario, numerically simulated in the ANSYS environment [2].

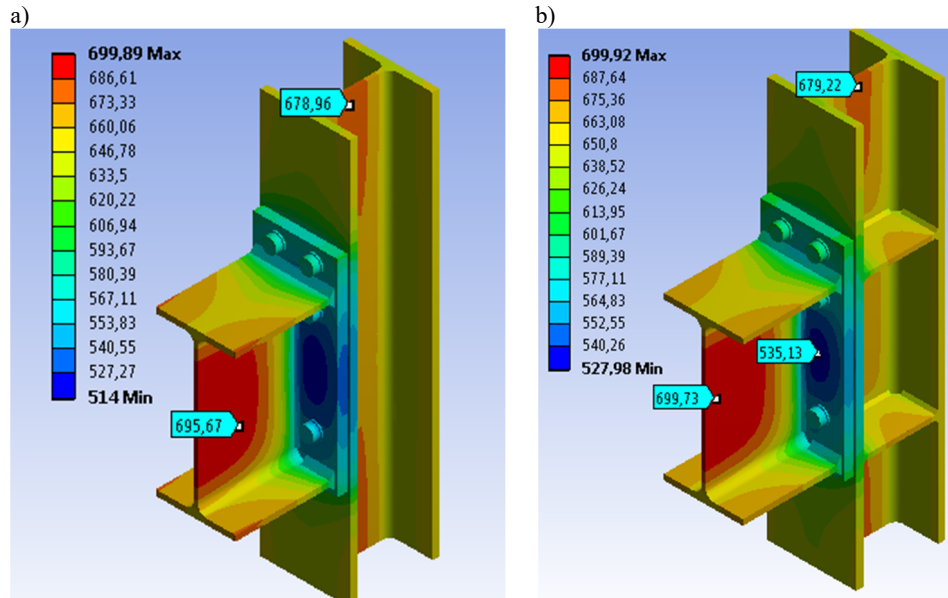

Fig. 4. Temperature distributions obtained after 15 minutes of a standard fire exposure in the models of a pure steel end-plate beam-to-column joints considered in the analysis (detailed description of such models is given in the text, simulation performed using the ANSYS environment [2]). In particular: a) model of a joint without the horizontal ribs stiffening the column's web, b) model of a joint with such the ribs

It is easy to notice that after 15 minutes of a simulated fire in both models the temperature value representative for a joint end-plate turned out to be lower, even by 150 degrees Celsius, compared to the other temperature value, representative for the beam web. This is due to the fact that in this joint zone the effective thickness of the heated steel plate is extremely high, because it is in fact the sum of the end-plate thickness and the thickness of the column's flange ( $20 \text{ mm} + 14 \text{ mm} = 34 \text{ mm}$ ). The addition of two horizontal ribs in this case facilitates the removal of heat from the joint end-plate giving an additional surface for radiating. As a consequence in the model presented in Fig. 4b the cooler zone in the joint end-plate was clearly smaller than that observed in the model shown in detail in Fig. 4a. Generally, it can be stated that the highest steel temperature in particular joint components is always identified in those plate zones where the distance from the adjacent walls increasing the heat dissipation is large enough and its value is the higher for the lower thickness of the heated plate. Comparative analysis of the model of an analogous steel end-plate joint

with reduced end-plate thickness (from 20 mm to 14 mm), which meant a reduction in the total thickness of the heated plate (from 34 mm to 28 mm, i.e. about 17%), resulted in an increase in the end-plate temperature by approximately 30 degrees Celsius, which is a roughly 5% change. Temperature differences identified at the bolts length are negligible, as shown in Fig. 5.

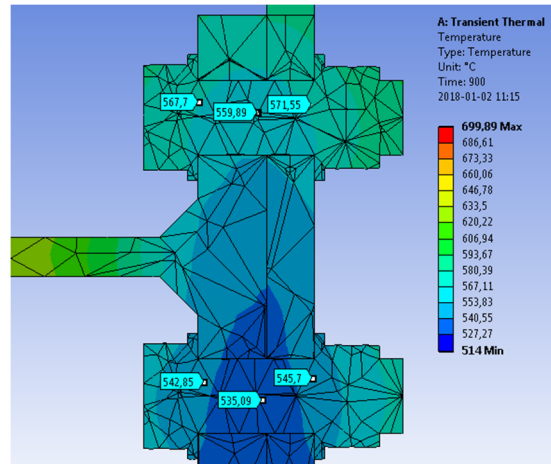

Fig. 5. Temperature distribution obtained after 15 minutes of a standard fire exposure for the joint model shown in detail in Fig. 4a in the cross section through the bolts axes. Only the bolts from the upper row, located above the top beam flange (shown on the left) as well as those from the intermediate row (located just below this flange) are visible (simulation performed using the ANSYS environment [2])

A detailed analysis of the temperature distribution in the pure steel end-plate joints presented in Fig. 4 allows to conclude that in the formal model describing their behaviour in a fire four basic groups of the joint components should be distinguished due to the different heating rate as is shown in Fig. 6. The I-beam web heats up by far the fastest among other joint components due to its low thickness. This is especially the case for beams made of the high plate girders, when the distance of the central area of the web plate from the much thicker beam flanges that cool such web in its edge areas is sufficiently large. It should also be noted that the relatively thick beam flanges in general heat up much faster than the joint end-plate. The effective heating of the joint end-plate, usually quite thick, is conditioned by the necessity of simultaneously heating the column flange adhering directly to it and generally no less thick. Differentiation in the heating rate was also observed between the particular rows of bolts. Those of bolts, which were located on the edge of the joint end-plate, outside the outline of the upper beam flange, heated up a bit faster than those located between the beam flanges, in the part shading such bolts from the direct exposure of a fire. Let us note that the difference between the temperature of the bolt and the temperature of the joint end-plate in its immediate vicinity is negligible.

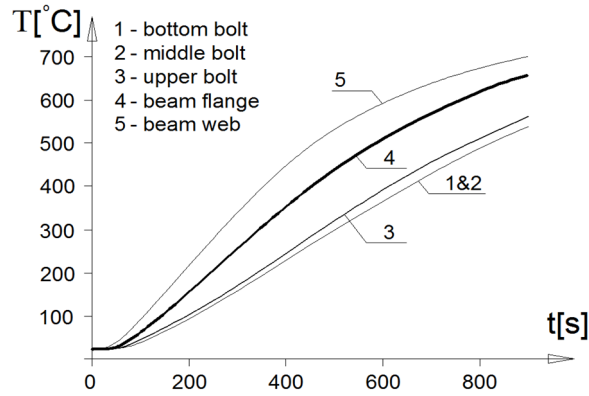

Fig. 6. Different heating rates in the numerically simulated fire of individual joint components in the case of the joint considered in the example and shown in detail in Fig. 4a (simulation performed using the ANSYS environment [2])

### 3. Heating of the beam-to-column steel end-plate joints covered by a reinforced concrete floor slab

Beam-to-column joints considered in the presented paper are usually covered from above by a massive floor slab made of the reinforced concrete with a large thermal capacity. As a consequence of such joint's configuration the joint components adjacent to this plate are usually much colder during a fire than those more distant from it. To verify this effect and to evaluate its importance for the global fire safety assessment a new model of the end-plate joint was developed, corresponding to the joint from Fig. 4a but with an added 150 mm thick reinforced concrete slab, composite with a steel frame beam (Fig. 7). It was assumed that this slab was made of concrete on a regular aggregate and with a density of  $2,300 \text{ kg/m}^3$ . In the fire conditions, the steel I-beam was heated on three sides and the floor slab absorbed the heat only from below. The temperature distribution obtained at the tested model after 15 minutes of a numerically simulated standard fire exposure is shown in detail in Fig. 7. As one can see, the cooling effect of the floor slab turned out to be very important and the difference between the steel temperature representative for the lower beam flange and the one observed in the upper beam flange was close to 250 degrees Celsius.

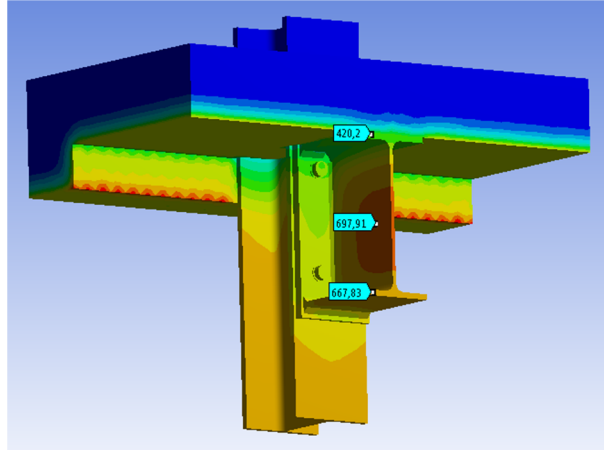

Fig. 7. Temperature distribution obtained after 15 minutes of a numerically simulated standard fire exposure in the end-plate joint covered from above by a massive reinforced concrete slab (simulation performed using the ANSYS environment [2])

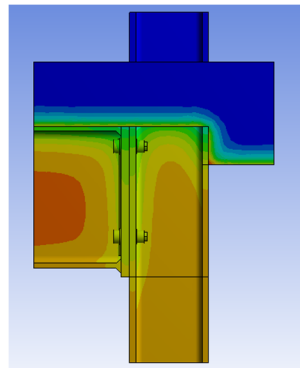

Fig. 8. Temperature distribution taken from Fig. 7 but visible in 2D side view of the joint (simulation performed using the ANSYS environment [2])

The influence of cooling a steel beam in the zone adjacent to the reinforced concrete slab is clearly visible in Fig. 8, where a side view of the considered joint after its 15 minutes fire exposure is shown in detail. In this figure, however, one can notice another interesting difference in the way of heating the neighbouring I-profiles of the beam and of the column. Under the same fire conditions, the column web does not heat up as intensely as the beam web, and as a result, as the fire develops, it becomes more and more clearly cooler. It is not only the effect of the slight difference in the thickness of both webs but also the fact that the considered column is made of a wide-flange profile. When describing the temperature development in the joint shown in Fig. 7, it is worth paying attention to the uneven temperature increase in the particular layers of a reinforced concrete floor slab. As can be seen in Fig. 9, concrete used in this

slab proved to be a heat insulator good enough that the effect of heating from the bottom is poorly noticeable in the upper layers of such a slab.

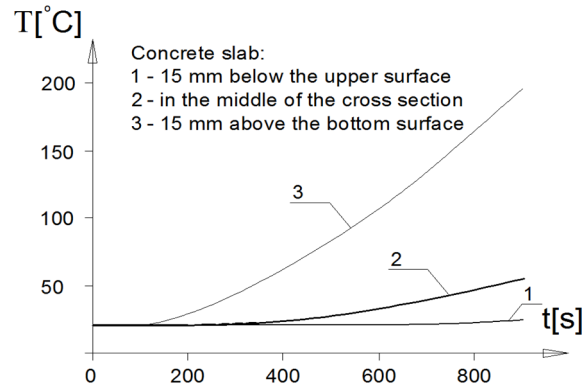

Fig. 9. Differences in the heating intensity in a simulated fire conditions of selected layers of reinforced concrete floor slab covering the considered joint (the results of the simulation performed using the ANSYS environment [2])

#### 4. Concluding remarks

The redistribution of internal forces in the members of a load-bearing steel frame structure subjected to fire is largely dependent on the real load capacity and the real stiffness of the joints connecting these members, which are changing with an increasing steel temperature [3, 4]. In order to predict it in a sufficiently reliable way, it is necessary first to define, and then to calibrate and finally to verify experimentally a suitably complex formal model that takes into account uneven temperature distribution in particular joint components, mainly in those joints that connect the frame beams and the frame columns. The assumption that the steel temperature in all the frame joints is fully evenly distributed and does not differ in value from the temperature identified in the same heating conditions outside these joints, commonly used so far in the fire safety analysis, in the opinion of the authors seems to be too simplistic and too conservative though it is always safe. For this reason, the authors recommend the use for this type of the structural analysis of specially specified nodal elements with precisely calibrated characteristics. Such characteristics could be selected on the basis of the appropriate numerical analysis, or, for example, in an analytical manner, using the procedures of the classical component method generalised for the fire case.

## References

- [1] Franssen J.-M., Gernay T.: Modelling structures in fire with SAFIR®: Theoretical background and capabilities, *Journal of Structural Fire Engineering*, 8(3), 2017, pp. 300–323.
- [2] Kohnke P. (Ed.): ANSYS®: Theory reference. Release 5.6. Canonsburg, PA, USA, November 1999.
- [3] Maślak M., Pazdanowski M., Snela M.: Redistribution of internal forces generated in a steel frame structure with flexible joints when exposed to a fire, in: Giżejowski M., Kozłowski A., Marcinowski J., Ziółko J. (Eds.) – Recent progress in steel and composite structures, *Proceedings of the 13th International Conference on Metal Structures (ICMS 2016)*, Zielona Góra, Poland, June 15-17, 2016, CRC Press/Balkema, Leiden, The Netherlands, abstract pp. 136-137, paper CD, pp. 315–322.
- [4] Maślak M., Pazdanowski M., Woźniczka P.: Influence of joint stiffness on the behaviour of steel bearing frame under fire conditions, *Ce/Papers, The Online Collection for Conference Papers in Civil Engineering*, Ernst & Sohn, A Wiley Brand, 1 (2017), No. 2 & 3, pp. 2811–2820.

*Przesłano do redakcji: 04.05.2018 r.*

*Przyjęto do druku: 15.06.2018 r.*